

An Improved Rudder Mixer



This document expands on the review by Alan Senior in his "Airwaves" column in the December 2014 issue of MMI (Marine Modelling International). In the period between submitting his review and it being published in MMI, I have incorporated some additional options to further enhance its operation as a result of some helpful feedback received from Alan during his review process.

The hardware has changed accordingly - a bank of 4 option switches now replaces the single option link selector and to make space for that, the rudder and throttle null setting potentiometers have been replaced by a single push button switch which serves to automatically null both channels. The null indicator LEDs, together with the push button switch, have been moved into vertical alignment with their corresponding input channels to better highlight their association.

Now read on !

Rudder Mixing Overview

In twin motored boats, a rudder mixer allows simple differential speed control of the two motors without the need of an extra throttle channel or alternatively the use of an upmarket transmitter capable of mixing channels at source. The basic concept is to mix the rudder (steering) demand in equal and opposite amounts with the throttle demand thereby creating two output channels which respond in unison to the throttle but differentially to the rudder. These outputs drive the two motors via their ESCs (Electronic Speed Controllers). Thus, for example, when turning to port the starboard motor speeds up and the port motor slows down to assist the turning action. If the boat is stationary, rudder application will drive one motor forwards and the other in reverse allowing most boats to literally turn on the spot.

Traditional Mixer Problems

At normal 'cruising' speeds I have found that the usual 100% (fixed) mix results in the boat accelerating whilst turning. In fact, at other than very modest speeds, rudder authority alone is usually sufficient to adequately steer the boat. This mixer offers an improvement to the commercially available rudder mixers I have thus far encountered, in that the proportion of rudder mixed into the throttle signals can be adjusted from zero to 100% by the user. So for example, after experimentation with their particular boat a user may find that a 60% mix gives a decent balance between low speed manoeuvrability and good steering behaviour when under way. The capability to adjust up to 100% mix is still retained for boats (or tracked vehicles) steered by differential motor control alone or those boats fitted with 'scale' rudders which prove to be woefully inadequate.

Another Control Option

The above problem of potentially excessive steering assistance at speed can be avoided if the user is prepared to sacrifice an additional channel to feed into the 'rudder' input of the mixer instead of the actual rudder channel itself. That way the user can choose to only invoke differential control when the boat is at low or zero throttle settings. This means the user controls the boat in a similar manner to one fitted with a bow or stern thruster.

Dynamic Mixing

I prefer the simplicity of controlling just the rudder, which in comparison to the above idea frees up a channel for control of other accessories. So, to have your cake and eat it, with this mixer the user can select a mode which adjusts the proportion of rudder mixing applied depending on the boat's speed. I refer to this as 'dynamic' mixing as opposed to the 'static' (i.e. speed-invariant) mixing offered by normal mixers. Thus at zero speed, 100% mixing is available for high manoeuvrability, tapering off to zero mixing at some speed that is set by the user (e.g. 40% of full speed) when they find that rudder authority alone suffices to steer the boat in question.. An example of a user control being speed dependent is the so called "variable assist" power steering in cars – finger-tip light for parking but it has become re-assuringly firm at highway speeds. An option switch allows the user to select either static or dynamic mixing and a single potentiometer serves to adjust the proportion of mix or the zero mixing cut off point for the static and dynamic options respectively.

Nulling Rudder and Throttle Channel Offsets

With centred joysticks and centred trims - which is how most users prefer to have their transmitter set up - very few transmitters actually output a precise 1.5mSec pulsewidth (dead centre of the 1.0mSec to 2.0mSec range which is the industry standard). So the rudder mixer has a push button which can be used at any time to automatically null out any offsets in the throttle and rudder signals to the mixer. When the throttle and rudder channels are correctly nulled this is indicated by a pair of associated LEDs and the resultant speed demand to the two ESCs will be 1.5mSec or zero ('neutral'). To prevent inadvertent setting of grossly inappropriate nulls, this nulling capability is restricted to operation in the 1.4mSec to 1.6mSec range only. After nulling the mixer, the two ESCs may need to have their neutrals reset. Those ESCs that auto adjust their neutral each time at power up should be ok as the mixer initially outputs a 1.5mSec signal (see 'Power-Up Issues' below)

Power-Up Issues

The majority of 2.4Ghz RC systems are aimed at model aircraft (you will find channels marked “elevator” and “aileron”!) and at power up, before the receiver has ‘booted up’ and locked in, the receiver’s throttle channel often outputs a 1.0mSec signal, which corresponds to the safe situation of a closed throttle - for electric powered aircraft that is. However, for boats this corresponds to full reverse throttle!

Thus at power-up the mixer initially outputs a 1.5mSec pulse train ('neutral') to the ESCs which prevents an unexpected and rapid journey in reverse which would probably swamp the stern of the boat. It also allows those Mtroniks 'plug and play' ESCs to initialise correctly – the latter set their 'neutral' based on the pulse width they first see at start-up, so were you to connect that type of ESC to your receiver you would end up with a forward only speed control operating over the entire range of the joystick – as some modellers have found to their bewilderment!

This 1.5mSec pulse train continues until such time as the receiver’s throttle output falls within the 1.4mSec to 1.6 mSec range, which occurs when the receiver has locked in - assuming that the joystick is in its neutral position that is (otherwise the 1.5mSec pulse train will continue until it is). This also prevents full speed astern being selected if the boat is powered up without the transmitter having been turned on. The throttle null LED flickers very rapidly during this start-up phase whilst the receiver is trying to lock in and will continue thereafter until the throttle joystick is centred.

Not all 2.4Ghz RC systems are subject to this “fail-safe” behaviour of starting up with a closed aircraft throttle, and 27Mhz and 40Mhz sets assert their correct joystick positions immediately at power-up, but the mixer aims to deal with the worst case scenario.

The Hardware

As can be seen from the photo the unit utilises a small flanged ABS box which will afford protection against accidental shorting and/or moisture though it is certainly NOT waterproof! Two 100mm male/male leads are supplied to connect mixer's throttle and rudder inputs to the corresponding input channels on the receiver. A 3 pin header immediately adjacent to the rudder input is an output to drive the rudder servo. Note that in certain configurations (see later) the signal driving the rudder servo can be static (amidships) or reversed by the mixer, so a Y lead from the receiver's rudder channel should NOT be used to drive the rudder servo if the mixer is to work correctly in all configurations. The ESCs are plugged into the two ESC output headers.

As well as the “throttle in” there is a “throttle out” connector for driving an engine sound unit. This output follows whichever of the two (mixed) motor speed demands is the faster. This avoids a problem were the sound unit to be fed by a simple Y lead from the receiver's throttle channel. Consider the case where the boat is at a standstill, the throttle channel in neutral position and the sound unit at tickover. Application of full rudder would cause one motor to go full ahead and the other to go full astern – the props would be thrashing the water, the boat would be spinning on its axis but the engine sound unit would still be at tickover as the throttle channel is still at neutral. Similarly, using a Y lead from one of the mixer's two ESC outputs creates a different problem - whilst cruising if the boat is turned in one direction the engine sound would (correctly) speed up but turning in the other direction it would slow down and vice versa. Thus the “throttle out” facility should be used if the sound unit is to correctly reflect the engine speeds. Users of sound units where the speed demand is derived from the motor terminals directly should connect up the mixer using the basic installation diagram given below but note that they will be affected by the second issue described above.

Wiring Diagrams (signal flow only)

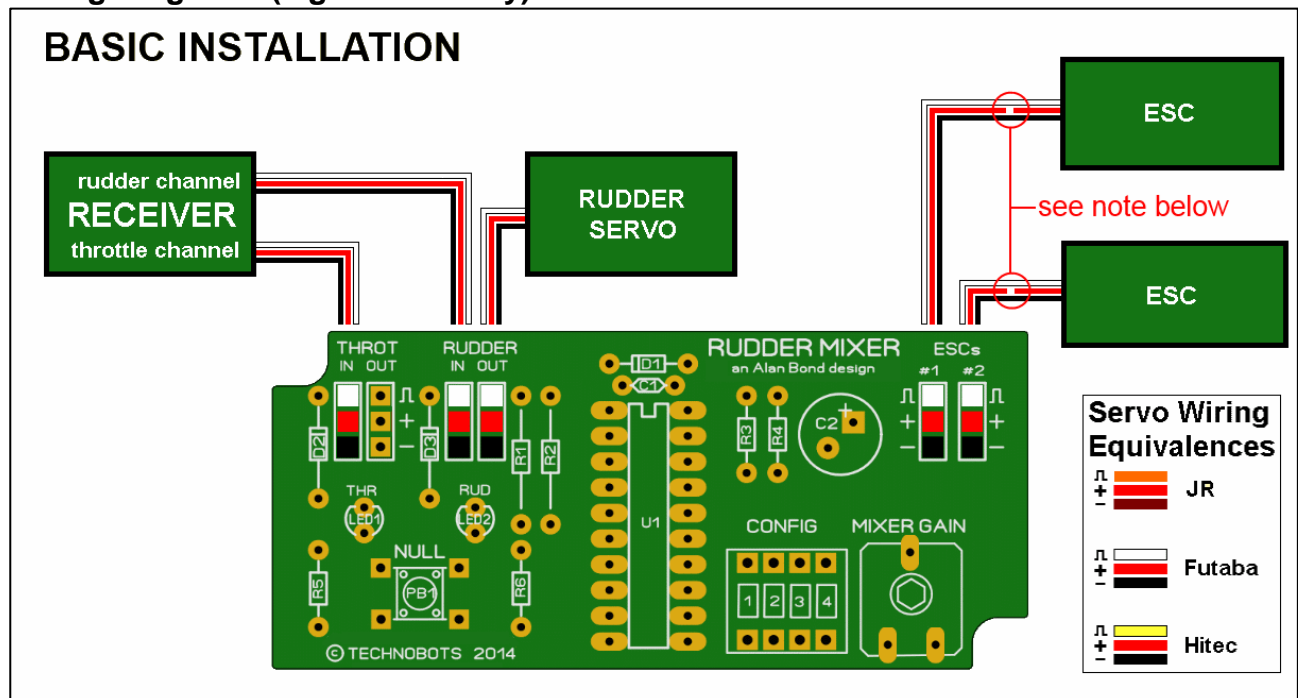

Note: if both ESCs have an integral BEC (battery elimination circuit) then one of the BECs should be disabled by removing its red wire from its plug – otherwise the BECs will “fight” each other. If supplying the receiver’s 5v supply from a separate battery box and either or both of the ESCs contain integral BECs then the BECs should be disabled. There must be only ONE 5v supply in the installation.

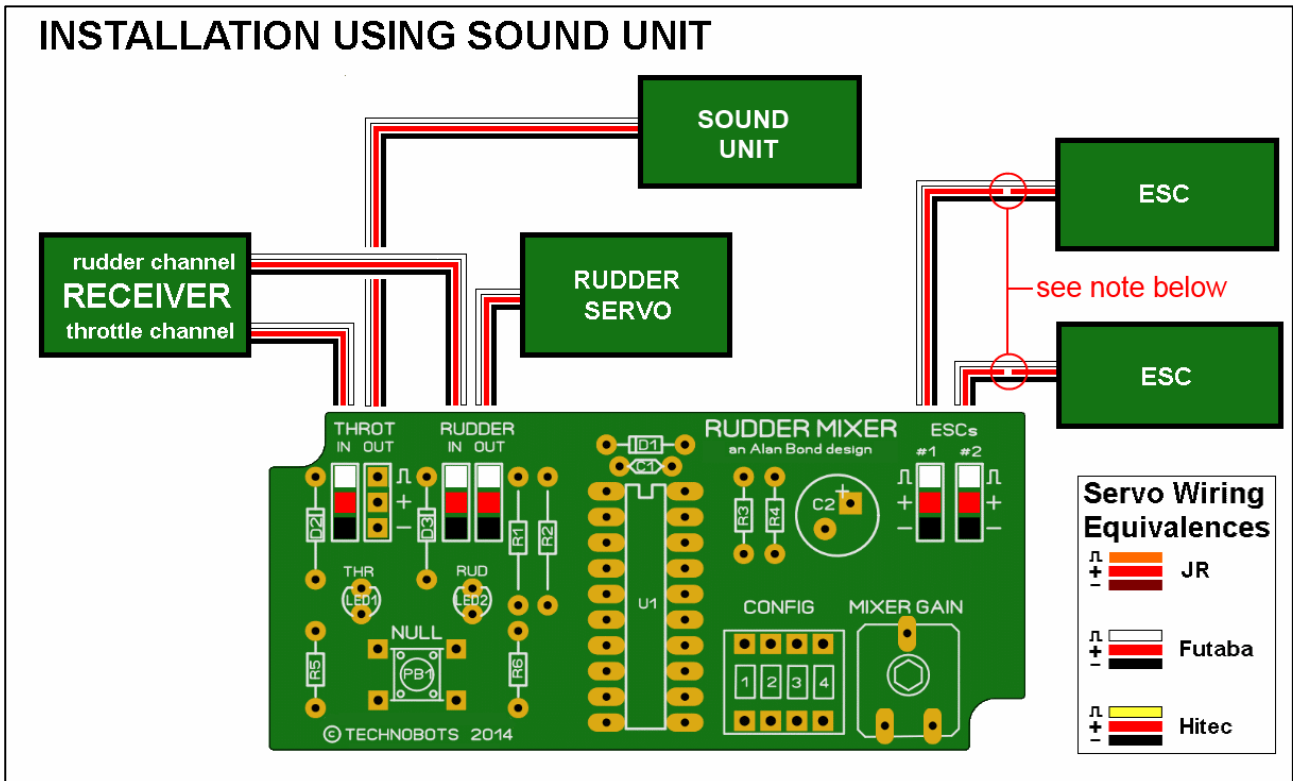

Note: if both ESCs have an integral BEC (battery elimination circuit) then one of the BECs should be disabled by removing its red wire from its plug – otherwise the BECs will “fight” each other. If supplying the receiver’s 5v supply from a separate battery box and either or both of the ESCs contain integral BECs then the BECs should be disabled. There must be only ONE 5v supply in the installation.

Plugging Up

Care should be taken when connecting the (supplied) mixer leads to the receiver. If the latter is a typical aircraft type with no shrouding around the channel outputs, then it is easily possible to misalign the mixer lead by one position. This can result in the 5v supply being shorted out and if this condition persists, apart from nothing working, the receiver leads may well melt – especially if a battery box is being used. With this in mind, when fashioning the cut-out slots in the box lid do not make them so large that it is possible to misalign the leads onto the throttle, rudder and ESC headers in the mixer.

With the JR/Futaba/Hitec connector configuration, no damage should occur if a lead is plugged in upside down (which can be done if there is no flange on the plug and corresponding slot in the receptacle).

Discussion of Mixing Options

The model aircraft world offers inexpensive and widely available mixers which are often used by the model boating fraternity. These are usually of the “V-Tail” variety, and whilst perfectly suited to model aircraft, when used in a boat a minor drawback occurs.

Whilst moving ahead the differential motor steering and the rudder steering act in unison but when travelling astern the differential motor control steering is in opposition to that afforded by the rudders and as the rudders have very little authority when going astern the motor steering dominates the situation and overall the steering acts in the reverse sense. However, dealing with this steering reversal is just as intuitive as having to move the stick in the opposite direction when a forward moving boat is coming towards you and most (v-tail) mixer users don’t in fact realise that the steering sense reversal has occurred when going astern.

However boats using steerable kort nozzles (and I don’t have one or know of one to try!) may well exhibit significant rudder authority in reverse which would tend to cancel the motor steering leaving the user with little or no control at all. So with such boats in mind, two possible workarounds are to either (automatically) fix the rudder/kort amidships whilst the boat is moving astern and rely on motor steering alone or to (automatically) reverse the physical rudder/kort movement whilst the boat is travelling astern such that rudder authority can further assist the motor steering. In both cases the sense of steering still remains reversed, but user control is restored.

These two workarounds are equally applicable to boats without steerable kort nozzles and do improve the astern steering experience.

An alternative mixing algorithm is available, which I’ve dubbed ‘Marine’. This time the motor and rudder steering remain in unison whether going ahead or astern and the steering sense is likewise maintained. However this gives rise to an unpleasant handling situation whereby moving from ahead to astern (or vice versa) whilst there is some rudder deflection causes an instantaneous and violent switching of motor direction. I and other users I know have found this undesirable, but it is recognised that some users may prefer using the vessel with this type of control, choosing to operate it in such a way as to avoid the sudden motor direction switching.

Thus by way of the option switch bank the mixer offers both of these mixing algorithms plus the v-tail workarounds for the user to determine which method of control suits them best.

The dynamic mixing concept has already been introduced, but one possible drawback is that if the mixing has been set up to cease employing motor assistance at fairly low speed, then whilst going astern at speed, the user has only got rudder steering for control and (steerable korts excluded) this is likely to be very ineffective. Thus a further option exists for the dynamic mixing to only operate in the forward direction and motor steering to be maintained throughout the speed range whilst travelling astern. The astern steering assistance can be set in 10% increments up to 100% of full power. Whilst intended for use with dynamic mixing, it was considered useful to extend the above idea to all the other options.

The amount of astern steering assistance is set by holding the null button pressed at switch on. The two LEDs blink in unison about once per second. Each blink represents a setting of 10% and the releasing the button fixes the percentage of reverse steering assistance reached and stores it in memory. So to set 50% for example, hold the null button pressed, switch on, count five blinks and release the button.

To more easily understand the interplay of the various ideas described above, the diagrams below graphically illustrate the range of options available with this mixer. These are shown for the two cases of V-Tail and 'Marine' mixing.

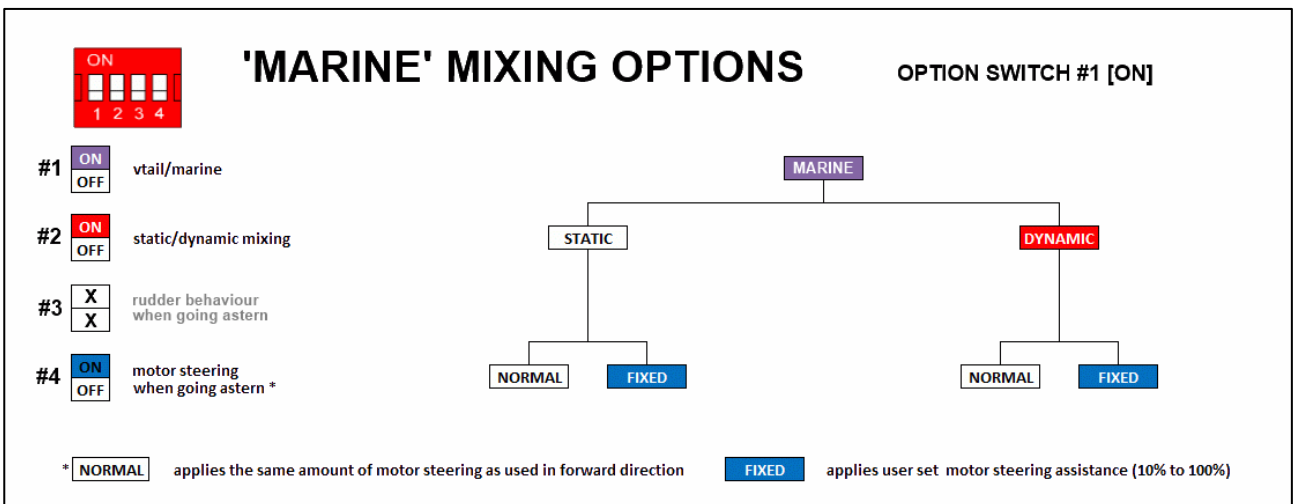
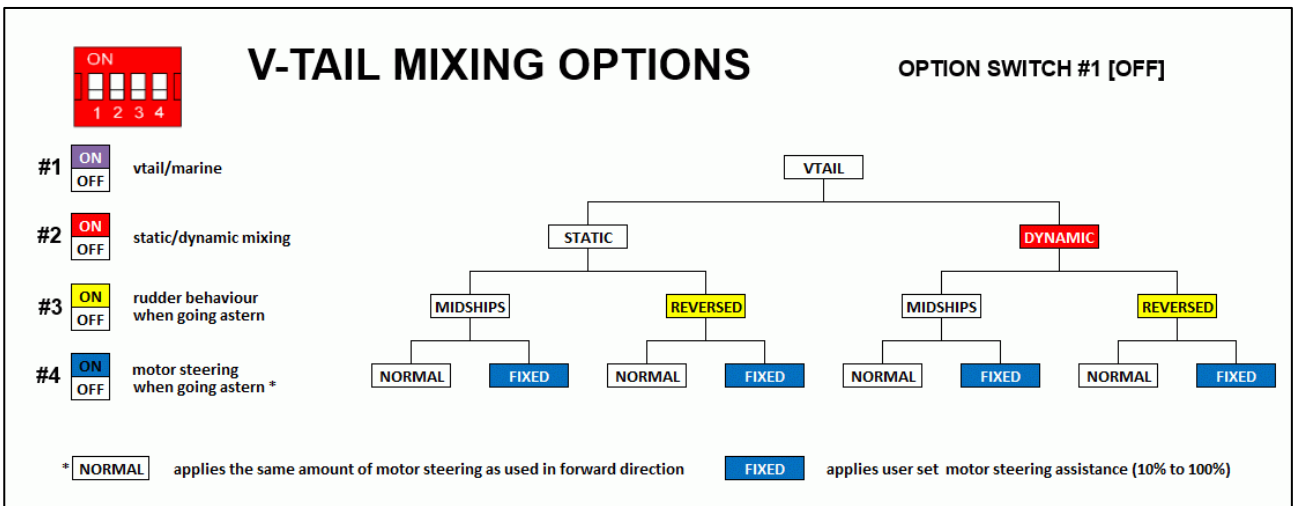

Bench Trials

As mixing can be processed differently in ahead and astern, it is important that your transmitter throttle channel does not have its channel reversing switch in use. If after de-activating the channel reverse switch the boat runs in reverse, then swap the motor leads around to correct the situation.

The option switches are continuously sampled so they may be altered at any time, having immediate effect.

Initial trials are best conducted with the case removed so the option switches, the null button and the mixer gain pot may be easily operated. Once the unit is set to the user's satisfaction the case can be fitted. The only subsequent adjustments that may be needed are to reset the rudder and throttle nulls to accommodate minor system drift or to adjust the mixer gain. A small hole may be drilled in the case lid above the nulling push button to allow access to it with a matchstick or similar non-metallic tool. The mixer gain pot spindle protrudes through the case lid but can no longer be finger adjusted – however there is a small screwdriver slot in the exposed head of the spindle than can be used.

Begin with v-tail and static mixing modes selected (all option switches OFF) and the mixer gain pot turned down to zero (fully anticlockwise). Use the transmitter trim to get the (physical) rudder pointing dead ahead. When this has been achieved, the null pushbutton may be used and both LEDs should illuminate. The speed controllers may then need to have their neutrals reset for zero motor speed. Under user control, the motors should now run forward and reverse in unison and be completely unaffected by operation of the rudder.

Now increase mixer gain to full and view the boat from the stern. With throttle at neutral, moving the rudder to one side should cause one motor to run in forward and the other in reverse, the opposite situation occurring when moving the rudder the other way. Then apply throttle for about one quarter ahead and then gently move the rudder from side to side. Note the physical rudder deflection and check that the motor on the outside of the projected turn speeds up and the inner motor slows down, stops and may even go into reverse with a large rudder input. You may need to swap the ESC#1 and ESC#2 outputs to achieve this.

At zero throttle, when moving the rudder from dead ahead, one motor may be noticed to start before the other – this is not a mixer problem, but is due to different friction characteristics in the (lightly loaded) motors and the prop shafts. When in the water these differences are very minor in comparison to the loads imposed by the water and the motors will start together.

Experiment with the setting of the mixer gain pot and note how it adjusts the proportion of motor steering assistance applied to rudder displacement.

Differential motor steering will be operative when going astern but the rudder will be fixed in the midships position. Turn option switch #3 ON and then note that rudder steering is now activated going astern but in the opposite sense to when the boat is travelling ahead. However, in either case it will be noted that rudder and motor steering are acting to reinforce each other.

When thoroughly familiar with static mixing behaviour, turn option switch #2 ON which selects 'dynamic' mixing and turn the mixer gain pot almost fully anticlockwise. This sets the mixing to have cut out by fairly low throttle settings and it is then easy to study the dynamic mixing behaviour. Rudder application at zero throttle should be as before but as the throttle is slowly increased, at each step the application of rudder has less and less effect on the speeding up and slowing down of the motors and finally none at all.

Again, experiment with the setting of the mixer gain pot and note how now, in dynamic mixing mode, it adjusts the cut-off point at which motor steering assistance ceases to be applied.

With an early (=low speed) cut-off point for motor steering, turn on option switch #4 and note that motor steering is now maintained throughout the speed range whilst going astern when the rudders might be expected to be ineffective. The factory default setting for this fixed motor steering is 50% as when on the water users might appreciate the steering being less sensitive as it's easy to get in a continual over-correcting situation (like when driving a rear wheel steering dumper truck). However this will depend on hull and rudder dynamics and users should experiment with different levels of assistance to find what suits them best.

The above bench exploration of the mixer functions can now be repeated with option switch #1 turned on. This selects 'marine' mixing where the sense of motor steering when going astern is correctly maintained at the expense of a violent jump in motor direction when going from ahead to astern (or vice versa) *but only if there is any rudder deflection at the same time*. In this mode the position of option switch #3 is ignored as the rudder and motor steering act to reinforce each other when going astern so the choice of work-around is not required.

On the Water

When testing the boat on the water, begin with the static mix option and 0% mixing and (in very light wind conditions so sideways drift is not an issue) check that you can get the boat to run dead ahead with the rudder joystick centralised – this is where you may choose to run with some (transmitter) rudder channel trim if you are unable to achieve straight running by push-rod or servo horn spline adjustment. If so, then null the mixer channels again before proceeding.

Now you can try setting a higher mixer gain and evaluate its improvement to low speed manoeuvring, whilst checking that turning behaviour at speed is not adversely affected – adjust the mix percentage until a good compromise is found.

It is suggested you become thoroughly familiar with the boat's performance under static mixing before experimenting with dynamic mixing. With correctly adjusted dynamic mixing you should be able to utilise full (100%) mixing at zero speed without compromising the turning behaviour of the boat whilst it is running at 'cruising' speed.

The choice of V-Tail or Marine mixing is left for the user to determine which suits them best.

Signal Range Issues

Mixing of signals is limited such that the resultant outputs to the ESCs never exceed the 1mSec to 2mSec range, so in other than zero throttle conditions one ESC output may at some point become clamped at its maximum whilst the other ESC output continues to change – this is quite normal.

Throttle or rudder inputs to the mixer which exceed the 1mSec to 2mSec range are initially limited to 1mSec or 2mSec for small exceedances but for gross exceedances on the throttle channel input the ESC outputs will revert to 1.5mSec (stop) and the throttle null LED will flicker rapidly to signal this condition. For gross exceedances on the rudder channel input the applied steering differential will be reduced to zero (ie the ESC outputs will reflect only the throttle input) and the rudder null LED will flicker rapidly.

In the event of complete loss of signal on either or both input channels, the associated nulling LED will flash slowly and 1.5mSec (stop and/or rudder mid-ships) signals will be passed to the ESC outputs. To avoid 'glitching', ten consecutive 'good' pulses must be issued from the receiver before normal operation is resumed.

Availability

The unit shown in the photograph features a professional etched, silk-screened PCB that will be used in the production unit. Should sufficient interest be shown I'm prepared to make a limited number of kits, say 20, available for user evaluation and feedback, prior to the mixer being put into full production and marketed by Technobots. At that point any software improvements that may result from the user evaluation will be incorporated. Units are planned to be available for evaluation in December 2014. Full production and corresponding availability from Technobots will be governed by how soon I get evaluation reports and the implementation of any software modifications judged necessary. Should software changes be made, trial participants will be given the option to upgrade to the final production software build by chip swapping at zero cost.

The kit will consist of an assembled and tested PCB, throttle and rudder leads to connect to the receiver and a blank ABS flanged box as seen in the photo - so users would need to make their own cut-outs to admit the throttle and rudder channel leads from the receiver, the actual rudder servo itself, two ESC leads and sound unit lead (if fitted), plus holes for the mixer gain pot spindle and LEDs.

For further discussion, contact me via email afbond@gmail.com. In assigning trial units I will give preference to supplying kits to address the widest possible range of vessels to optimise the evaluation process - so I need to have details of your model's size and running gear and your assurance that you will offer feedback on the effectiveness (or otherwise!) of the mixer and any clarifications that you feel the documentation may require.

